







Company Name			
Employee Names			
Team lead			
Module Name	Media		
Certification Test		Vendor	
Objectives covered			
Time allotted	10 Days	Time Taken	
Date Started		Date Completed	

Portfolio Contents

Item	Complete	Incomplete	Points Awarded
lab reports for all labs (list labs)			
Cable Characteristics			
Comparison of Wireless Networks			
Written test scores for each member (attach printout)	Score		

Completed solution to problem portfolio			
 Customer Overview			
 Jargon			
 Identify Customer Needs			
 Identify Possible Solutions			
 Define terminology used (jargon, technical terms)			
 Price Out Solutions			
 Diagram of Solutions			

Transmission Media

- *The stuff that carries _____ from computer to computer or device on a network.*
- *Different media is used by different kinds of _____.*
- *Is changing all the time. What is used today, will not be used tomorrow.*

When designing a network, keep these things in mind when choosing media

- _____
- _____ **requirements**
- _____ **needs**
- _____ **usage** (_____ / _____)
- _____
- **Immunity from** _____
- _____ *

Cost

- **Unfortunately, cost is usually the number _____ determinate of media type.**
- **Administrators need to do _____ benefit analysis on all segments of a network.**

Installation requirements

- **Many forms of media can be installed by the network administrator.**
- **Some will require special training and or technicians**
- _____ **Optic**
- _____ **Pair (relatively easy, but requires some knowledge)**
- _____

Bandwidth

- **Bandwidth is the measure of the _____ of a medium to transmit data. (How much can it send, and how fast can it send it.)**
- **Usually measured in _____ Per Second**
 - **Kbps**
 - **Mbps**
 - **Gbps**
- **Bigger is better...but ya gotta pay to play!**

Band Usage

– _____

– _____ **channel is used for all communications.**

- _____ transmissions are _____ pulses or _____
- _____, but not at the same time (_____ duplex)
- Most networks up to this point are _____ *

Band Usage

— **Broadband**

- Multiple _____ are used via _____
- _____ transmission are _____ or _____
- For _____ duplex transmission is sent over more than one _____ or more than one _____ (one to send, one to receive)
- _____ domain multiplexing allows more than one piece of data to hang out on the cable at the same time using different _____ *

Baseband vs Broadband

Simplex, Duplex, Half Duplex

- _____ —*Broadcast message that goes out to all the computers on the network, but they don't respond to it; one way communication.*
- _____ *duplex—each device can send and receive, but not at the same time*
- _____ *duplex—both devices can send and receive at the same time**

Attenuation

- _____ *is the how much a signal weakens as it travels away from the origination point.*
- *Larger LANs are going to have greater _____ problems.*
- *Sometimes solving big attenuation problems is cheaper by installing more _____ media.*

EMI

- *Electromagnetic “_____” which can cause signal degradation.*
- *Also known as “_____ talk” if the EMI comes from another cable sending network signals.*
- *Can be solved or lessened with _____ on cable types.*

Security

- _____ *media is more secure because in order to tap into it you have to be able to _____ access it.*
- _____ *is not as secure because eavesdropping is relatively easy.*

Three Main Types of Cable Media

- _____ **Cable**
- _____ **-Pair Cable**
- _____ **Optic Cable**

- **All have their plusses and minuses.**

Coaxial Cable

– **Types**

- _____
- _____

Thicknet

- **Very _____, but rarely used**
- **Uses a _____ cable and a _____ tap to connect to the backbone (thicknet cable)**

Thinnet

- _____ **and flexible**
- **AKA _____ - _____**
- **Installation-- _____**
- **Cost-- _____**
- **Range— _____ meters (about 610 feet)**
- **Speed— _____ (Arcnet) - _____ (Potential, Ethernet)**
- **EMI— _____, so not very sensitive.**

— **Connectors**— _____ **T and** _____ **-Barrel**

— **Eavesdroppers can pick up signals***

Fire Codes

- _____ **gives off poisonous gasses when heated or burned.**
- **Cables with PVC coatings cannot be installed in the** _____.
- **Cable in the plenum must be “**_____ **rated.”***

STP vs UTP

STP

- **Cost-** _____ **than UTP**
- **Install-** _____ **easy**
- **Speed-** _____, **up to** _____
- **Range-** _____
- **EMI-** _____ **sensitive than UTP**
- **Sometimes known as** _____ **cable**

UTP

- **Cost-** _____
- **Install-** _____ **easy**
- **Speed-** _____, **up to** _____
- **Range-** _____

- **EMI-** _____ **sensitive of all cable type***

Installation and Connectors

— **IBM Connectors**

- _____ **Connects** _____ **cable to NIC**
- **IBM** _____ **Connector connects to** _____ **cable**
- *Ethernet*
 - _____ **connectors connect to NIC and** _____ **drops, hub, switch, or patch panels.***

Why Twists?

- **Copper cabling very** _____ **to EMI**
- **Twisting** _____ **crosstalk**
- **The more twists per foot, the more** _____ **to EMI***

Fiber Optic

- **The most** _____ **material currently available for data transmission.**
- **No** _____ **problems at all**
- **Can run up to several** _____ **without attenuation problems.***

Fiber Optic Cable

- **Cost—** _____ **cost of any cable**

- **Installation**— _____ **and** _____
- **Bandwidth**— _____ - _____ **Mbps**
- **Attenuation**—Up to _____ **of Km potential**
- **EMI**—**Completely** _____ **to EMI or eavesdropping.**

Types of Fiber

- _____ **-Mode—Small core that allows only one beam of light to shine through. Shines in a single beam like a flashlight using a laser light (not used much).**
- _____ **-mode—larger core that allows multiple lights to shine through. Light bounces around as it travels down the media. Uses LEDs to transmit data.**
- _____ **mode is faster and can go over longer distances.**
- **Rate of transmission is determined by** _____ **and whether** _____ **or** _____ **fiber core is used (** _____ **is faster)***

Fiber Architectures

- _____
 - **Max cable length 40 KM**
 - **Uses SMF (single-mode fiber optic**
 - _____
 - **MMF (multi-mode fiber)**
 - **Max cable length 300 meters**
 - _____
 - **Single mode fiber**

– **Make cable length of 10 KM ***

Review is good for the soul

- ***Which is the most expensive cabling?***
 - ***Which is most susceptible to crosstalk?***
 - ***Hardest to install?***
 - ***Max length of UTP cat five?***
 - ***Cable that works with BNC connectors?***
 - ***Insulation around a fiber cable***
 - ***What type of band usage allows multiple signals over one channel?***
 - ***What type of band usage allows only one signal?***
- ***What is often the most important consideration when choosing media types?***
- ***What are the other considerations (5)?***

- ***What kind of connectors do UTP cables use?***
- ***What are the speed specs for UTP cable?***

- ***Which UTP cable category is most commonly used?***

Bounded vs Boundless Media

- ***Bounded is _____ media (UTP, STP, fiber)***
- ***Boundless refers to _____ media***
- ***What are some kinds of boundless media in use today?***

Boundless or Wireless Networking

– **Options**

– _____

– _____ **Frequency**

– _____

– _____

– _____

– _____ **Radio**

– **Most commonly used is** _____ *(Bluetooth PANs) and* _____
Frequency (802.11's)

802.11s

– **Original 802.11—Wireless LANs which provide** _____ **Mbps transmission using the 2.4GHz band using frequency hopping spread spectrum (** _____ **) or direct sequence spread spectrum (** _____ **)**

– **802.11a—Provide up to** _____ **in the 5Ghz band. Uses orthogonal frequency division multiplexing encoding**

– **802.11b—Provides** _____ **transmission in the 2.4Ghz band. Uses only**

- **802.11g**—Applies to wireless LANs and provides up to _____ in the _____ band.
- **802.11n**—A newer modulation technique that runs in the _____ range at _____ Mbps and has a current range of less than _____ feet. In 2/07 the final draft was opened and closed to technical comments on March 9, 2008. Expected release date is May 2009*

Wireless Network Security Protocols

- _____ —**Wired Equivalent Privacy**
 - Not really WEP
 - Vulnerable to _____ and _____ attacks
 - Uses a stream _____ which is easy to crack with the right software
- _____ —**Wi-Fi Protected Access**
 - Different _____ are distributed to each user, or you can use a _____ (PSK)
- _____ —**Implemented with _____ in an effort to truly make wireless as secure as wired networking**
- _____ (**extensible authentication protocol**)
 - Works with _____ and _____ -2 to really secure the networks
 - Both are used in _____ and _____ networks.
 - Uses a _____ and works with Apples and PCs
- **Security using PSK (pre-shared key)**

- Good for home offices, small businesses that don't have servers
- A passphrase is required to access the network (8-63 characters)
- Vulnerable to password hacking*

Wireless Network Topology

– *Ad-hoc*

- No single _____ points
- _____ connect to each other
- _____ —all wireless nodes are in direct communication with each other.

– *Infrastructure*

- _____ access points
- _____ —the topology is similar to a star in that one or more devices connect to a single access point

Other Types of Wireless

- _____ —*Travels at 10GHz to 1GHz*
- _____ —*Requires line of site between microwave towers, connects buildings with regular LANs, require licensing approval*
- _____ —*Expensive! Most companies must lease satellite space*
- _____ —*10Mbps-16Mbps, uses either broadcast or point to point**

Moving Data on the Physical Layer

- *It takes more than just a NIC and cables to transmit data.*

- ***Different networks use different methods of transmission.***
- ***Each of these methods have their pros and cons.****

Three Main Types of Access Methods

- ***Contention***
- ***Polling***
- ***Token Passing***

Contention

- ***Any _____ can transmit at any _____***
- ***In other words, _____ “make a run for it” and hope they don’t run into anyone else.***
- ***If other computers are transmitting at the same time there could be problems.***
- ***Used in _____ LANs****

Two Types of Contention

- _____ —***Carrier Sensing Multiple Access with Collision Detection***
- _____ —***Carrier Sensing Multiple Access with Collision Avoidance****

CSMA/CD

- ***Used in _____ LANs***
- _____ ***to the network as they are transmitting***
- ***If a signal is detected, _____ stops***

- **Good for _____ busy networks.**
- **As the network gets busier, the _____ increase.***

CSMA/CA

- **Used in _____ LANs**
- **Listens _____ transmitting to _____ collisions.**
- **If a transmission is _____ on the network, waits for a given time period and then listens again.***

Polling

- _____ **before sending on the network.**
- **Polling causes a LOT of _____ traffic, which can slow down the network.***

Token Passing

- **Used in _____ Ring LANs**
- **A frame called a “_____” is passed around the lab.**
- **Each computer must wait until it receives the token before it can _____.***

Networks that use Token Passing

- _____ **Ring--Most common. See 802.5 for information on Token Ring Networks**
- _____ **802.4—Not used often, but a few still out there**
- _____ **—Very fast demand priority fiber standard using a double token ring configuration**

Token Benefits

- _____ *access to all computers*
- *Able to use* _____ *priority*
- *Very busy networks—keeps from* _____ *down*
- *When carrying* _____ *critical data that is imperative it be received*

Auto-reconfiguration

- *Computers on a token network receive transmissions every* _____ *seconds.*
- *If a computer dies, it is removed from the* _____. *When it comes back, it won't receive packets.*
- *If 7 seconds pass and it hasn't received a packet it sends out a “*_____ *” packet with its address and the address of its nearest upstream neighbor*
- *By doing this, the network can determine where the problem is and usually automatically reconfigure the network to include that computer.**

Contention

- *Good for* _____ *usage LANs*
- *Much* _____ *cost*
- _____ *reliable*

Token

- *Good for* _____ *usage LANs*

- _____ **cost**
- _____ **reliable**

Review

- **Name the three types of access methods?**

- **Which is used in Ethernet?**
- **What is the difference between CSMA/CA and CSMA/CD?**

- **In token ring, if a computer has data to transmit it must do what?**

- **Which is better, token or contention?**

- **Polling adds a lot of _____ traffic to a network.**
- **More expensive, token or contention?**
- **More reliable, token or contention?**
- **Does the data travel with the token?**
- **Types of LANs that use token.**

- ***Types of LANs that use contention***

Lab 2-1 Hands On Cable Media Lab

In this lab activity you are going to examine several types of cables and describe their physical characteristics.

Building a Network Cable

1. Check out from me:

- A crimper
- Wire cutter
- Two RJ-45 heads
- A length of network cable
- A cable tester

1. Go to your computer and take a look at the network cable. Find the standards TIA/EIA568A and B. Which standard is used in this lab? TIA/EIA568A or TIA/EIA568B? _____

How To Make A Category 5 / Cat 5E Patch Cable

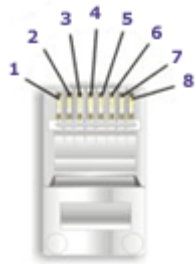

568-B Wiring

Pair #	Wire	Pin #
1-White/Blue	White/Blue	5
	Blue/White	4
2-Wht./Orange	White/Orange	1
	Orange White	2
3-White/Green	White/Green	3
	Green/White	6
4-White/Brown	White/Brown	7
	Brown/White	8

< 568-B Diagram

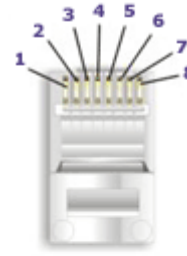

568-A Wiring

Pair #	Wire	Pin #
1-White/Blue	White/Blue	5
	Blue/White	4
2-White/Green	White/Green	1
	Green/White	2
3-White/Orange	White/Orange	3
	Orange/White	6
4-White/Brown	White/Brown	7
	Brown/White	8

< 568-A Diagram

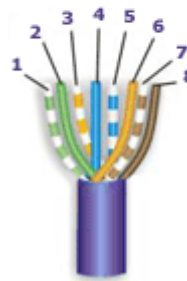
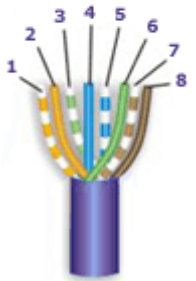

Notes For Wiring Diagrams Above:

1. For patch cables, 568-B wiring is by far, the most common method.
2. There is no difference in connectivity between 568B and 568A cables. Either wiring should work fine on any system*. (*see notes below)
3. For a straight through cable, wire both ends identical.
4. For a crossover cable, wire one end 568A and the other end 568B.
5. Do not confuse pair numbers with pin numbers. A pair number is used for reference only (eg: 10BaseT Ethernet uses pairs 2 & 3). The pin numbers indicate actual physical locations on the plug and jack.

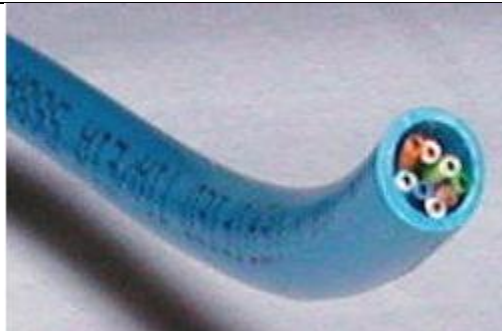

Cut the cable to the length that you will need.
If you are planning to use boots, this would be a good time to slip them on.
Place each boot facing "out" on the cable.



Skin the cable using the stripper (sheather) about half an inch down. Don't squeeze! You don't need to squeeze. Just fit the cable in and twirl.

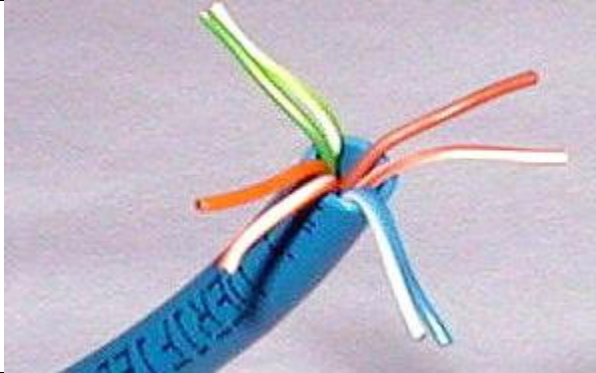

Untwist each pair of cables, being sure NOT to untwist them down into the sheath.

If you're using Cat6 there is a spine that needs to be removed. Cut down as close to the cable ends as possible.



Spread out the cables so they're easier to work with.

Put them into the proper order, depending on if you're doing 568a or 568b. See wiring diagram above.

The photo shows 568-B the most commonly used.



Right!!!



WRONG!!

Insert the wires into the head:

1. Hold the connector so the clip is pointed away from you and the opening is towards the floor.
2. Hold onto the jacket tight so your cables don't jingle up.
3. Slide the cables slowly into the head working them all the way to the end.
4. Look at the side of the connector facing you and check that the cables are in the proper color order.
5. Check one more time.
6. Have a friend check.
7. Look at the end and make sure you can see the copper circles pushed ALL the way to the end.
8. Make sure the jacket is INSIDE the RJ45 connector.
9. If something is messed up, pull it out and start again. If the jacket doesn't fit into the connector, pull it out and trim down your cables a little

Slide the head into the crimper and make sure it's all the way in.

Crimp down HARD.

Pull it out. If the head falls off, you didn't crimp enough.

Each head can only be crimped one time so be extra sure you're ready to crimp!

Test your cable with the cable tester.

1. Insert both ends into the tester.
2. Hit test.
3. For a straight through you should see a straight wire map.
4. Bring to me and have me test it to make sure it works.

TIA/EIA 568A Wiring



TIA/EIA 568B Wiring

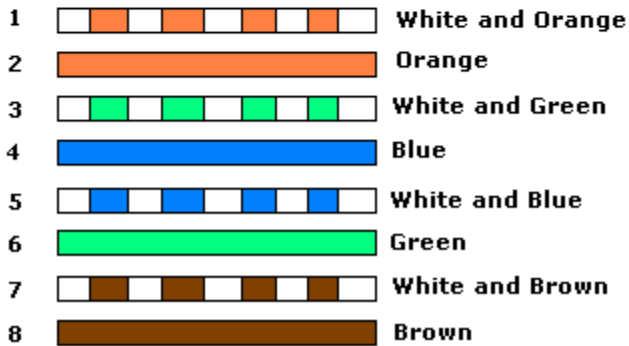

Crossover Cable:

1. One head is 568-A
2. One head is 568-B
3. The “swapped” cables ensure that when you pair like devices (switch to switch, computer to computer) they will transmit and receive on the proper pins.

Cut off one head (keep the best one)

Wire that head 568-B if the other is 568-A.

Notice in the diagram one end is B (the left) and the other is A.

Label the cable below based on YOUR cable you just created. You'll need this for the next step.

Pin #	Color	Pair #	Function
1			
2			
3			
4			
5			
6			
7			
8			

Station Three—Create a Crossover Cable

In a crossover cable, the send and receive pairs are switched. Why? If you are connecting a like piece of equipment to a like piece of equipment, you need something to switch that signal. You'd use a crossover cable to connect computer to computer, hub to hub, router to router, etc.

1. Get two more RJ 45 heads from me. You are going to create a crossover cable so you can connect one computer to another.
2. Using the information from above and the picture on page 121, create a crossover cable.
3. Connect your cable to two computers. Try to ping from one computer to the other. Now ping back. Does it work?
4. Save your cables you created.

Station Four—Let's go Shopping!

You are going to go online and use catalogs to compare the prices of the types of materials you just used. Find the prices for the following:

Item Description	Catalog/URL	Company	Price
100 feet Category 6 UTP Cable (PVC, not plenum rated)			
100 feet Cat6 STP Cable			
1 RJ-45 Connector			
1 BNC T-Connector			
1 BNC Terminator			
1 foot fiber optic cable (multi-mode 50 micron cable)			

Label the Cables

A



B



C



D

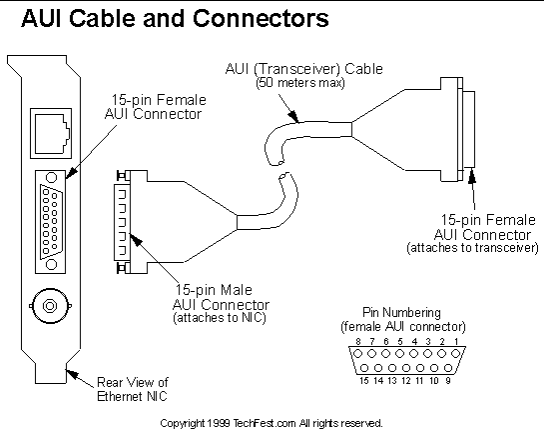

2-2 Identifying Cable Costs

In this project, you use the Internet to identify cable characteristics and associated costs.

As a network administrator, you will need to have a detailed knowledge of network media and their associated connectors. When you are called upon to troubleshoot or implement a network, this knowledge will prove invaluable.

A common task for network administrators is to source out the costs of cable and connectors. Consider the following scenario: You have been contracted by SnickCo, a maker of snowshoes and toques, to begin the process of implementing a network. SnickCo requires a network of 30 systems and needs to know the costs associated with the media for the network. The network will require both UTP and 20 feet of STP cable.

Estimated time: 20 minutes

1. Get on the Internet and from a search engine, look for a company that sells network cable. The search is likely to return many results, and it may be necessary to restrict your search to local vendors.
2. Browse a vendor's Web site and locate UTP Category 5/5e and STP cable.
3. To connect 25 systems with UTP cable, you need 25 patch cables. To connect other network devices, you need additional cables.
4. Continue to search the site for the costs for the STP cable. To get a better idea of costs, it might be necessary to find information from several vendors.
5. Compare the cost of buying bulk cable and connectors to the cost of buying pre-made cables and connectors.
6. Create a spreadsheet that details the cost for the company.

Lab 2-3 Understanding Wire Placement in 10BaseT Cabling

Work as a team on this one. Gather together

- 🔗 10 Feet of Cat5 cable
- 🔗 Four RJ-45 Connectors
- 🔗 Two computers running Windows 2000 or XP
- 🔗 Crimper and wire stripper
- 🔗 Make sure you've done the Hands on Cable Media Lab

Estimated time: 35 minutes

1. Using just one end of the cable, refer back to Lab 2-1 to create one good end of a twisted pair cable.
2. On the other end, use a crimping tool to create a cable with a wiring diagram like this one:

Pin Number	Pair Number	Color
1	4	Brown
2	4	White/Brown stripes
3	1	White/Blue stripes
4	3	White/Orange stripes
5	3	Orange
6	1	Blue
7	2	White/Green stripes
8	2	Green

3. Log into each computer as an administrator.
4. Change from the domain to a workgroup. Name both computer workgroups **labgroup**.
5. Right click my computer. Click networking tab. Click change button. Type in workgroup name.
6. Restart both computers.
7. Log onto the computer locally (see me if you need to).
8. Double click on My Network Places. Can you see the other computer? _____
9. Ping the other computer using the command prompt and the ping (ping IP address of computer). Do you get a ping reply?

10. Cut the bad head off the wire. Create a working wire.
11. Reconnect. Now can you see the other computer? _____
12. Ping the other computer. What response do you get?

13. Which wires/pins were "damaged" in this lab?

14. In the diagram below, label what each of the wires in a Cat5 Cable is responsible for.



Number	Purpose
1	
2	
3	
4	
5	
6	
7	
8	

Get a cable tester from me and test that your cable works correctly.

Lab 2-4 Testing for IP Address and Connectivity

Using the cables you created, do this lab. This will tell you for sure that your cables are working and give you some insight into Windows Server 2008.

1. Start up your server.
2. Go to the command prompt.
3. Type pathping nettech01
4. What does it say?

5. Now type tracert nettech01
6. What does it say?

7. Do this at home (since it's blocked because of our proxy).

- a. Pathping www.teechur.com
- b. Tracert www.teechur.com

8. Attach screen shots.

Open the command prompt again. You're going to use the ARP protocol and command to resolve an address to a MAC address. ARP stands for Address Resolution Protocol.

- 9. At the prompt type **arp -a**
- 10. Write down what you see.

11. Using this screen, what is the MAC address of your server? How can you tell?

12. Type **arp /?** Write down the switches you can use after /

13. Write down the switches you can use after -a

14. Configure your computer for static addressing.

- a. Open your control panels
- b. Go to the Network and Sharing Center
- c. Click Manage Network Connection
- d. Right click on your network connection and select properties.
- e. Double click on Internet Protocol Version 4 (TCP/IPv4)
- f. Assign the IP address as follows:

Pod	Addresses	Subnet Mask	Default Gateway	DNS Server
A	10.10.1.2 10.10.1.3 10.10.1.4 10.10.1.5 (be sure each computer has a different one)	255.255.255.0	10.10.1.1	10.10.1.2 10.10.1.3 10.10.1.4 10.10.1.5
B	10.10.2.2 10.10.2.3	255.255.255.0	10.10.2.1	10.10.2.2 10.10.2.3

	10.10.2.4 10.10.2.5			10.10.2.4 10.10.2.5
C	10.10.3.2 10.10.3.3 10.10.3.4 10.10.3.5	255.255.255.0	10.10.3.1	10.10.3.2 10.10.3.3 10.10.3.4 10.10.3.5
D	10.10.4.2 10.10.4.3 10.10.4.4 10.10.5.4	255.255.255.0	10.10.4.1	10.10.4.2 10.10.4.3 10.10.4.4 10.10.5.4
E	10.10.55.2 10.10.55.3 10.10.55.4 10.10.55.4	255.255.255.0	10.10.55.1	10.10.55.2 10.10.55.3 10.10.55.4 10.10.55.4

15. Click okay.
16. Open your command prompt.
17. Type IP Config
18. Write down:
 - a. IP Address v4

 - b. IP Address v6

 - c. Subnet Mask

 - d. Default Gateway

So what are these????

- A. Subnet mask tells a router what network you live on. Since your subnet mask is 255.255.255.0 that means that you are in network 10.10.4.0 (if your IP address is 10.10.4.2-10.10.4.254. the 255s “mask” off the part of the address that says “I live in this network”. The 0 masks off the part that identifies your computer in that network.

So on the following IP Address and subnet mask:

192.168.1.1 255.255.255.0

What part is the network?

What part is the host (or computer)?

- B. Default Gateway: This is the address of the router that allows you out of and into the network. When we set routers up in our networks, they will be assigned this address. Usually they get the network address with the host of 1.
- C. DNS Servers: The DNS server has a table of DNS entries...IP addresses matched to computer names. So if your computer name is **PICKLE** and your IP address is 10.10.10.1 the DNS server would be able to tell other computers looking for PICKLE that it lives at 10.10.10.1. You will set up DNS on one server in your network and have the others replicate the directory. We'll do that later.

Questions

1. What does pathping do?
2. What does tracert do?
3. How many hops from your computer to www.teechur.com? (For example, I just did it from mine and it was 23 hops! Wow!)
4. What is a hop?
5. What does ARP stand for?
6. What does ARP do?
7. What is your IP address in V4?
8. How did your computer get a V6 address?
9. What is the default gateway?
10. What is a subnet mask?
11. What is the NETWORK part of the IP address (v4) assigned to your computer?
12. What is the HOST part of the IP address assigned to your computer?

13. What does a DNS server do?

Lab 2-5

Check out a Fluke OneTouch Series II Network Assistant from me.

Treat it as if it were made of glass because it's worth more than you are. ☺

Test Your Cable

14. Test the regular cable you made by plugging in both ends to the top of the tester.
15. Turn on the testing device.
16. Push **with your finger only, no stylus or pencils or pens** Wire Tests.
17. Click Wiremap cable
18. Draw what you see below

19. Did it give you any errors?
20. Does this cable pass?
21. Now get your crossover cable. Do the same thing.
22. Draw what you see below.
23. Why does it look different?

Get an IP address from our network

1. Get a regular cable and plug into one of the ports on your switch. Make sure your switch is connected to our network (csn.com).
2. Go to the setup folder.
3. Click IP setup.
4. Hit DHCP
5. Click Get Address
6. What address did the server assign to your device?

7. Click log. What is the IP address of our DHCP server (hint...where it got the address FROM).

Cable Characteristics for 802.3 Standards

Fill in the table below for the characteristics of different types of cables related to 802.3 (Ethernet) standards.

Standard Type of Cable	Installation	Connectors	Range	Capacity	Cost (high/low)	EMI (resistant?)	Notes (required)
10BaseT <i>Type of cable:</i>							
10BaseTX <i>Type of cable:</i>							
10Base2 <i>Type of cable:</i>							
10Base5 <i>Type of cable:</i>							
100BaseFX <i>Type of cable:</i>							
Gigabit Ethernet <i>Type of cable:</i>							

Comparison of Wireless LAN Standards

Go online to <http://www.vicomsoft.com/knowledge/reference/wireless1.html> and http://www.webopedia.com/quick_ref/WLANStandards.asp and read the articles on wireless networking. Fill out the information below and answer the questions.

Type	Data Rate	Modulation Scheme	Security	Pros and Cons
802.11				
802.11a				
802.11b				
802.11g				
Bluetooth				
802.11n				

Transmission Media Case Study

Your firm has been contacted by the company of This is Yours, That is Mine. They are a growing legal firm. Your job is to read the scenarios below (you will do each of them) and to identify the issues that need to be dealt with and choose the appropriate media to solve the problem. You will then do a very short presentation on your group decision.

Directions

1. Read the scenarios.
2. Write down all of the issues related to that scenario.
3. Choose an appropriate transmission media (bounded or boundless).
4. Fully describe the media you chose including:
 - a. Characteristics
 - b. Cost
 - c. Installation requirements
 - d. Bandwidth
 - e. Band usage
 - f. Attenuation
 - g. Immunity from EMI
5. Explain why you chose the medium you chose over other transmission media available.
6. Prepare a portfolio including each solution.
7. Include a spreadsheet for cost of each item. This will take some digging, but it's out there...trust me. I know these things.

This is Yours, That is Mine Legal Firm

Scenario One

The firm is small, but growing. All of the lawyers, paralegals, and assistants in the firm have a need to access a centralized database. Since they are experiencing a lot of growth they want a media that will expand as their needs grow, however cost is a big issue. They don't want to spend too much on the network at this point.

Scenario Two

It's two years later. Business has been great! The company is moving to a high rise office complex. They have a need to occupy two floors. Unfortunately the floors are 8 stories apart. Both floors will have their own LANs, which will need to be able to communicate with each other. The budget is higher this time, but the sky is not the limit. Since they are handling some big clients, they need to make sure all of their data is kept secure as it leaves the two individual LANs. Because the walls of the building are not conducive to pulling new cable, they will have to run some above the ceiling in the drop space.

Scenario Three

Five years later the firm is a power to be reckoned with. They now have offices in three different areas in the country. Each of the offices needs to be able to communicate with each other 24 hours a day. The data to be sent must move as quickly as possible. In addition, it must be on a secure form of transmission.

Scenario Four

The firm has moved even further out in the field. One of the areas they are now representing is Environmental Crimes. This can take lawyers into the field worldwide in a variety of situations. Because of the pressing nature of these cases, they need to have a way to access the company network from anywhere in the world. Often they find themselves out in the field away from any form of “normal” communication.

Scenario Five

The firm now has offices in almost every country throughout the world. They have begun an exchange program where lawyers take on cases in outlying offices to acquaint themselves with all aspects of the company. Each lawyer has a souped up laptop to take with her/him on these exchanges. They will need a temporary place to set up office and work.

Another issue is live video conferencing all over the world. Take into account that many countries do not have any kind of a network backbone in place.

Scenario Six

Jon Q. Gadget from the office has some specialized needs. He would like to be connected to the Internet at all times, since his job requires him to do a lot of research. He has a PDA and a cell phone, a tablet PC, and a Blackberry. He needs the ability to connect everything to each other and to the Internet. He wants to be able to get his email at any time, research through the Internet, connect to the network back at the office, use his cell phone in any country in the world, access everything even during travel.

Scenario Seven

The company has been working more and more in environmental crime, including investigations that are related to Homeland Security. All employees have been using passwords to enter the buildings, but those have become compromised again and again. The company is interested in a security scheme that can be a part of their network so that employees can enter access to specific areas of the building and that access can be tracked at any time. They do not, however, want outside forces to be able to sniff that access. Nor do they want the access to be dependent upon passcodes. For this scenario you'll need to describe what type of security measure to take, how it can be implemented into the network with what they already have. You'll want to talk to the other groups to determine what they are implementing.

Scenario Eight

Now the company is working with Homeland Security with some offices that have high level clearance for Top Secret government stuff. The employees who work there are required to have high security clearance and work with the understanding that while on the job, their position location will be logged at all times. Provide a solution that allows the employees to be tracked short-range on site.

Rubric (per scenario)

Component	Exceeds Expectations	Completely Meets Expectations	Shows promise	Does not meet expectations	Not Demonstrated
Description of scenario.	6	5	4	2	0
Outline of all issues that must be dealt with to provide a solution.	6	5	4	2	0
Description of solution to each issue.	11	10	8	6	0
Complete description of transmission media characteristics	11	10	8	6	0
Description of why this solution was chosen over other media.	11	10	8	6	0
Presentation includes all members of the firm.	16	15	12	9	0
Team members are able to answer questions proposed by annoying teacher.	16	15	12	9	0
Total points for scenario	/70				